

Truck Mounted Placing Boom

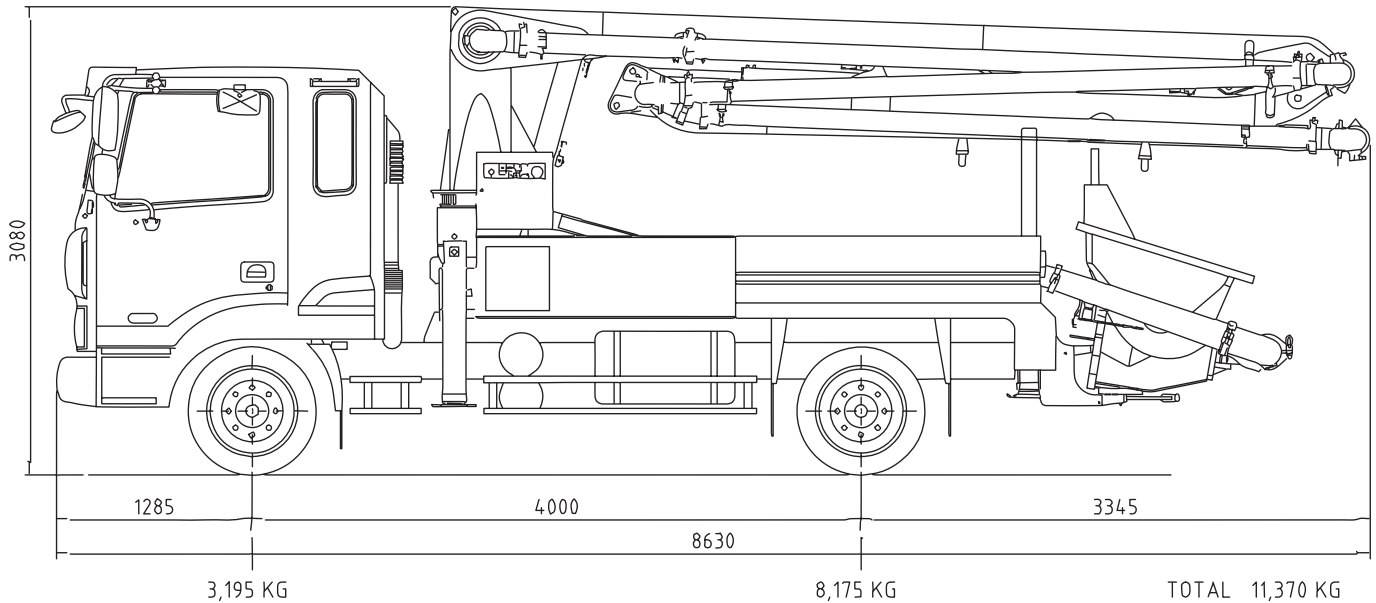

BOOM SPECIFICATIONS

Vertical reach	18.1M
Horizontal reach	14.8M
Reach from front of truck	12.1M
Unfolding height	5.15M
Section articulation	92°/190°/265°
Rotation	370°
Delivery line	104mm
Proportional boom	Yes
End hose length	3M
Outrigger spread-front	2.93M
Outrigger spread-rear	2.6M
Max. outrigger weight	9,000kg

PUMP SPECIFICATIONS

Maximum output	80m ³ /h
Concrete cylinder	Ø200 x 1100
Stroke per minute	38
Concrete pressure	71 bar
Hopper capacity	0.6m
S-tube	Ø200 x Ø150
Hydraulic pump	KCP - K3V200S
Cycling system	Hydraulic w/ manual overrides
Max. aggregate size	40mm

WORKING DIAGRAM

