

Truck Mounted Placing Boom

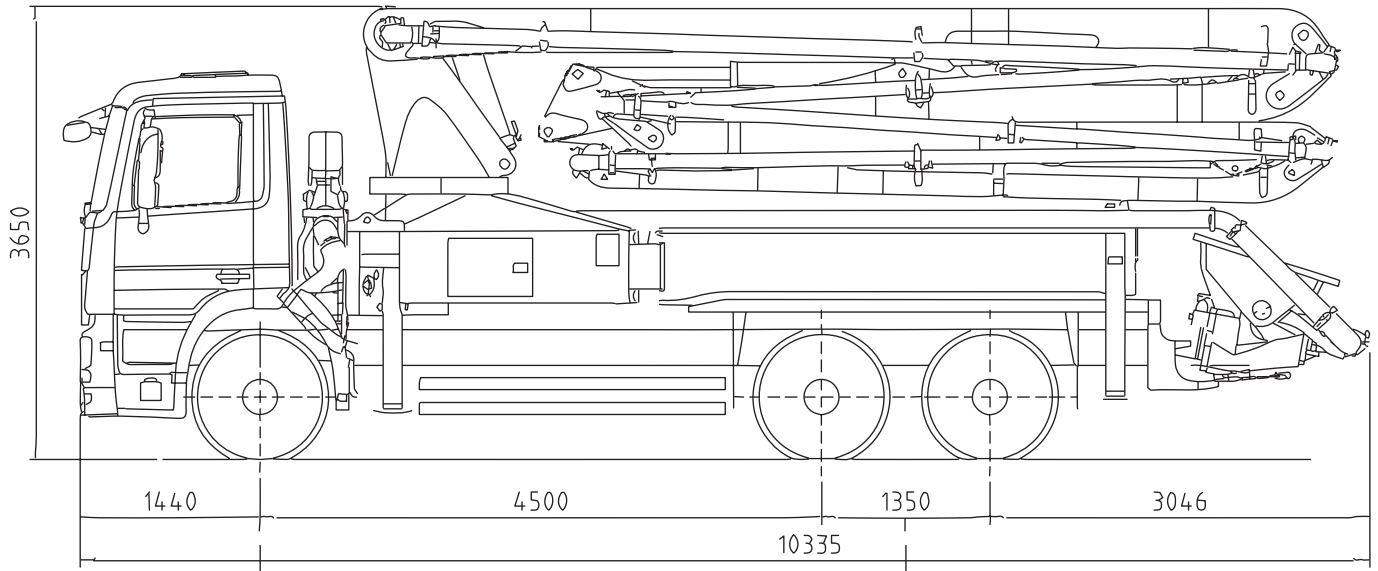

BOOM SPECIFICATIONS

| | |
|---------------------------|-------------------------|
| Vertical reach | 34.15M |
| Horizontal reach | 30.5M |
| Reach from front of truck | 26.7M |
| Unfolding height | 6.98M |
| Section articulation | 92°/180°/225°/180°/245° |
| Rotation | 370° |
| Delivery line | 125mm |
| Proportional boom | Yes |
| End hose length | 3M |
| Outrigger spread-front | 5.6M |
| Outrigger spread-rear | 6.77M |
| Max. outrigger weight | 16,000kg |

PUMP SPECIFICATIONS

| | |
|---------------------|-------------------------------|
| Maximum output | 150m/h |
| Concrete cylinder | Ø230 x 1800 |
| Stroke per minute | 33 |
| Concrete pressure | 70 bar |
| Hopper capacity | 0.6m |
| S-tube | Ø200 x Ø150 |
| Hydraulic pump | Rexroth-A11VLO260 |
| Cycling system | Hydraulic w/ manual overrides |
| Max. aggregate size | 40mm |

WORKING DIAGRAM

