

Truck Mounted Placing Boom

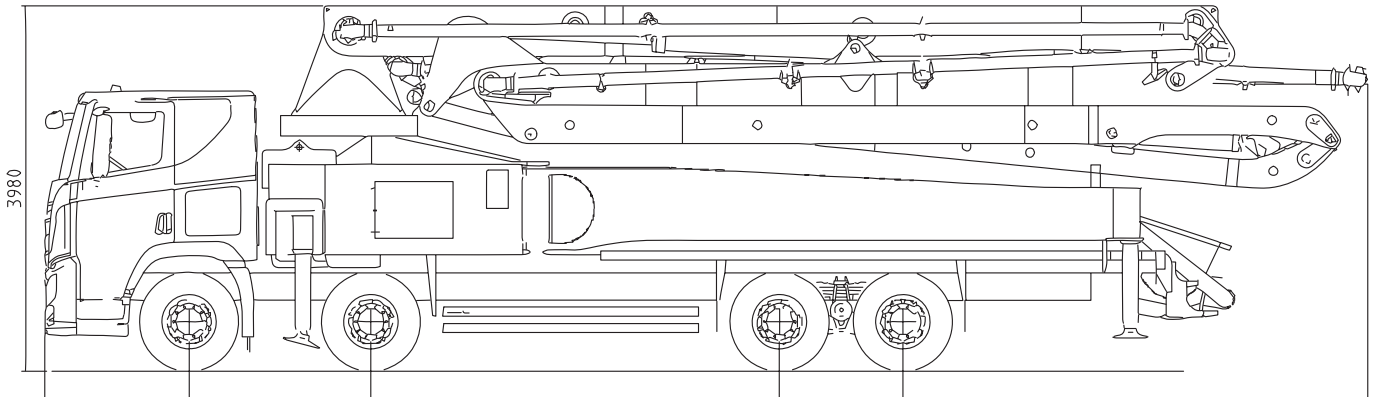

BOOM SPECIFICATIONS

Vertical reach	51.6M
Horizontal reach	47.5M
Reach from front of truck	44.6M
Unfolding height	11M
Section articulation	92°/180°/225°/180°/210°
Rotation	370°
Delivery line	125mm
Proportional boom	Yes
End hose length	3.5M
Outrigger spread-front	9.1M
Outrigger spread-rear	10.6M
Max. outrigger weight	38,000kg

PUMP SPECIFICATIONS

Maximum output	170m/h
Concrete cylinder	Ø230 x 2100
Stroke per minute	32
Concrete pressure	87.5bar
Hopper capacity	0.6m
S-tube	Ø200 x Ø180
Hydraulic pump	KCP-K3V180DT
Cycling system	Hydraulic w/ manual overrides
Max. aggregate size	40mm

WORKING DIAGRAM

