

## Stationary Line Pump

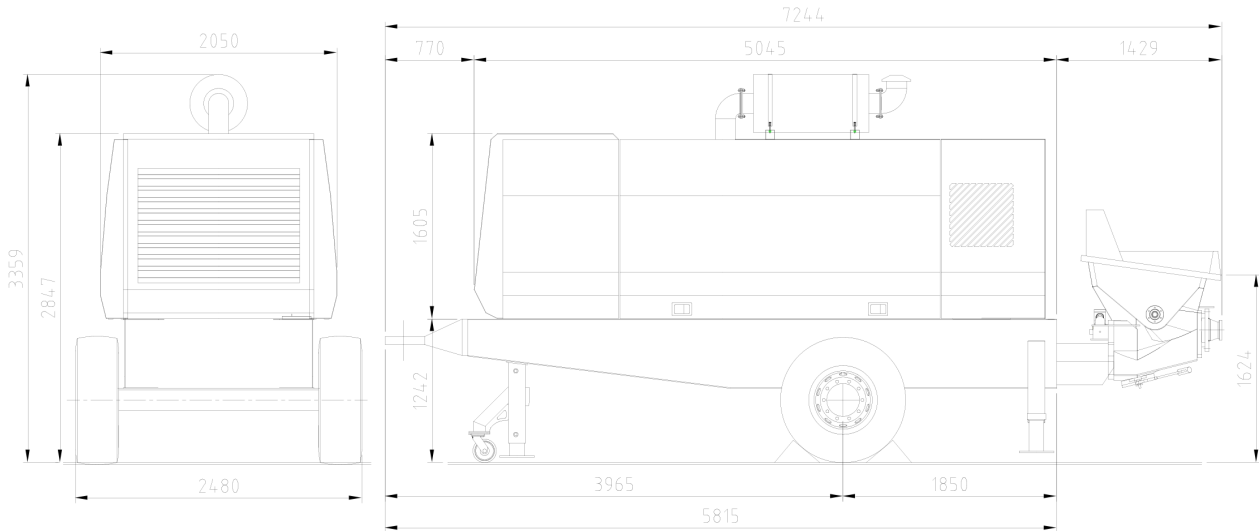

### PUMP SPECIFICATIONS

Engine	800HP DOOSAN
Engine RPM	1900 RPM
Maximum output	78m <sup>3</sup> /h(high), 125m <sup>3</sup> /h(Low)
Main cylinder	Ø180/Ø110 x 2100ST
Concrete cylinder	Ø200x2100ST
Cycling system	Hydraulic with manual overrides
Stroke per minute	20(High), 31(Low)
Concrete pressure	284 bar(High), 177(Low)
Hopper capacity	0.6m <sup>3</sup>
S-tube	Ø200xØ150
Hydraulic pump	KCP-K3V280DTH
Max. aggregate size	40mm

### PERFORMANCE DIAGRAM

